

STRONG AROUND THE WORLD

MEDIA PROJECTION SHELF

FEATURES

- Generously vented tray promotes free air flow to the projector prolonging equipment life through proper cooling.
- Height and incline adjustments allow precise positioning of the projection apparatus.
- Made with high quality steel and coated with a durable black powder coat finish.
- Supports up to 75 pounds (34 kg) safely, perfect for digital media projectors.
- Anti-Skid shelf surface.
- Multiple pre-drilled holes in mounting plate provide flexible installation options virtually eliminating the need to drill additional holes.
- Assembly hardware and instructions included.
- Can be used with most other manufacturer's port models.



Media Projection Shelf

Overview:

Strong's Media projection shelf is a high quality vented steel shelf designed for digital media projectors. This unit can support the average digital or slide projector safely and comes with pre-drilled holes for additional suspension if necessary. This projection shelf can be attached directly to a port or mounted below the window on the booth wall. An attractive black powder coat finish matches all Strong ports and provides a durable surface that resists scratching and abrasion.

Flexibility:

0-15 degree rear incline adjustment as well as 2 1/4 inches (5.7 cm) of vertical adjustment overall to meet your specific application's requirements.



a division of Ballantyne of Omaha, Inc.

Strong MEDIA PROJECTION SHELF



Ordering Information:

Media Projection Shelf	
86055	Media Projection Shelf

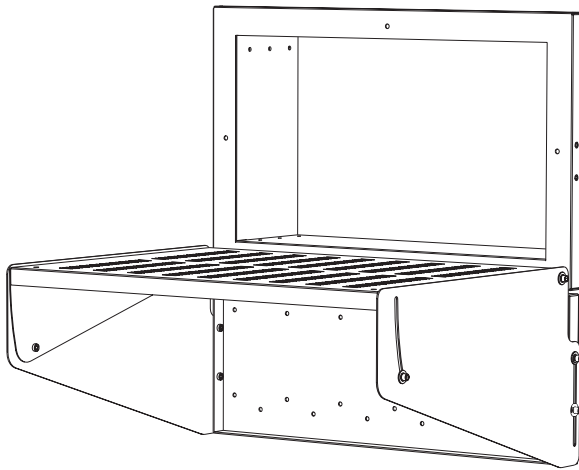

Media Projection Shelf
(shown attached to Projection Port)

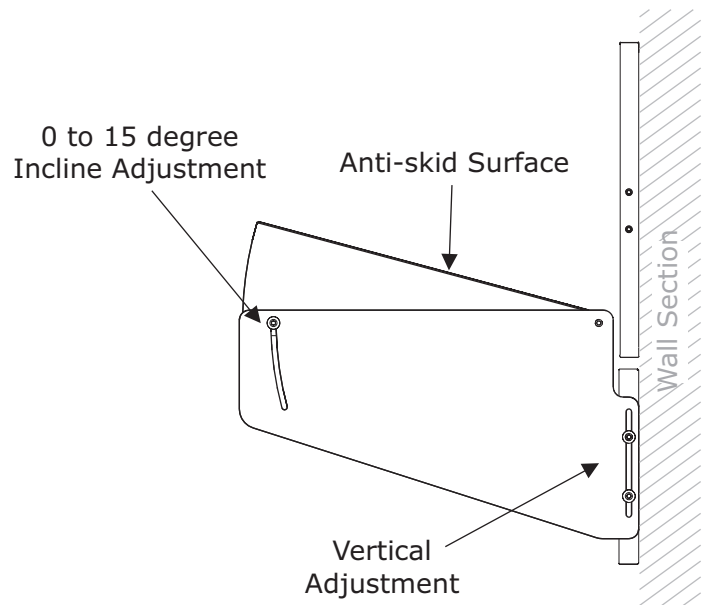

Dimensions:

Load Capacity: 75 lbs (34 kg)(Safety Factor 1.5)

Tray Area: 26 in W x 18.5 in D (66 cm x 47 cm)

Approx. Weight: 22.4 lbs (10.2 kg)